

BEFESTIGUNGSBOHRUNGEN DN 4-25

Befestigungsbohrungen von **OBEN**

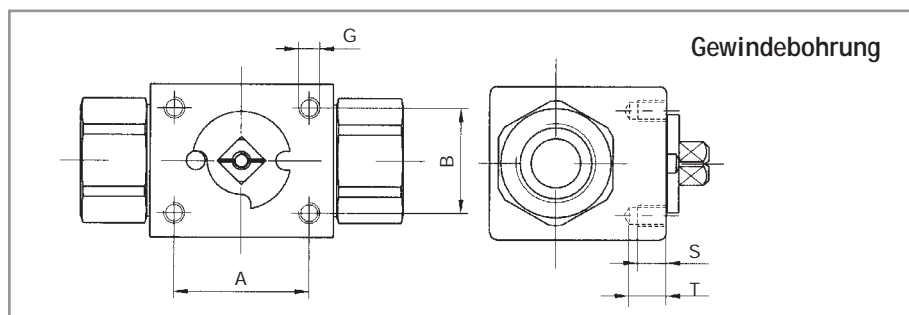

DN	A	B	G	S	T
4-8	26	18	M 5	6	8,5
10	34	24	M 6	8	11
13	34	24	M 6	8	11
16	34	24	M 6	8	11
20	45	38	M 6	8	11
25	45	38	M 6	8	11

Befestigungsbohrungen von **UNTEN**

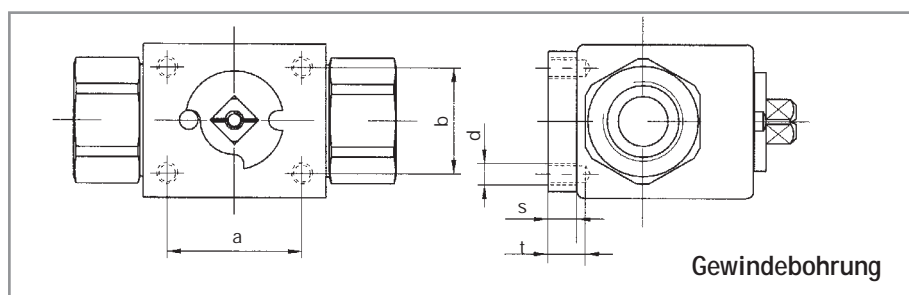

DN	a	b	d	t	s
4-8	24	20	M 6	-	6
10	34	24	M 5	7,5	6,5
13	38	27	M 6	7	6,5
16	38	27	M 6	7	7
20	51	39	M 6	11	8
25	52	48	M 6	11	8

Befestigungsmöglichkeiten **SEITLICH OBEN**

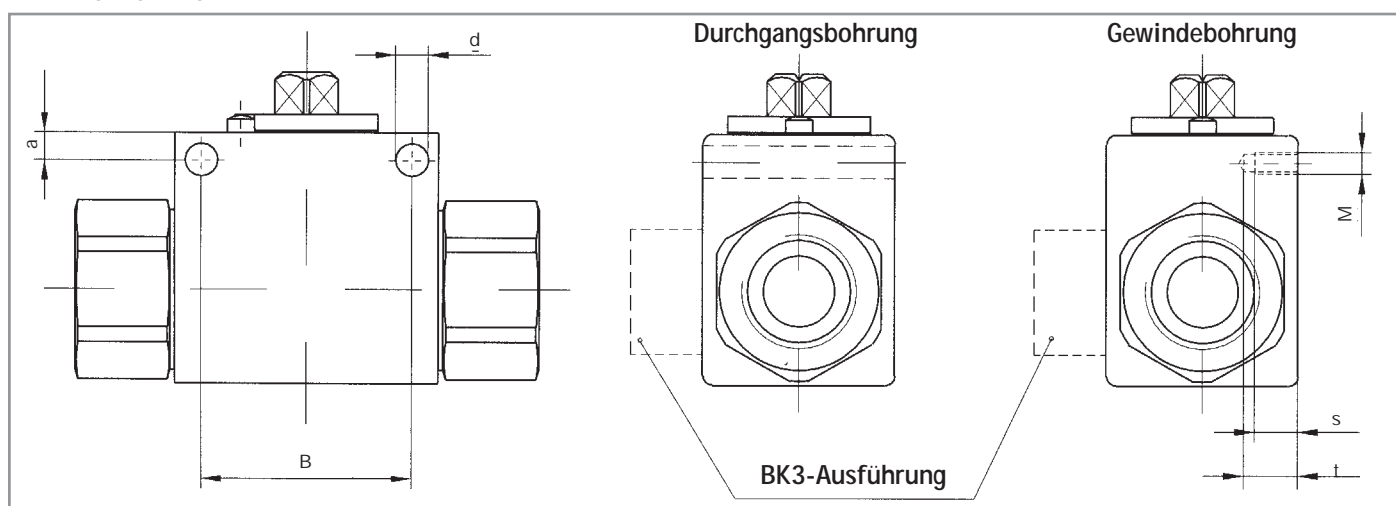

Durchgangsbohrungen

DN	B	a	d
4-8	26	5	4,5
10	32	5	6,5
13	37,5	4,8	6,5
16	37,5	5	6,5
20	45	6,5	6,5
25	55	6	6,7

Gewindebohrungen

DN	B	a	M	s	t
4-8	24	6	M 6	6,5	9
10	32	5,5	M 6	7	10
13	36	6	M 6	8,5	11
16	32	8	M 6	7	10,5
20	45	7,5	M 10	12	15
25	45	7,5	M 10	12	15

Maßänderungen vorbehalten.