

PLATTENKUGELHÄHNE BKHU

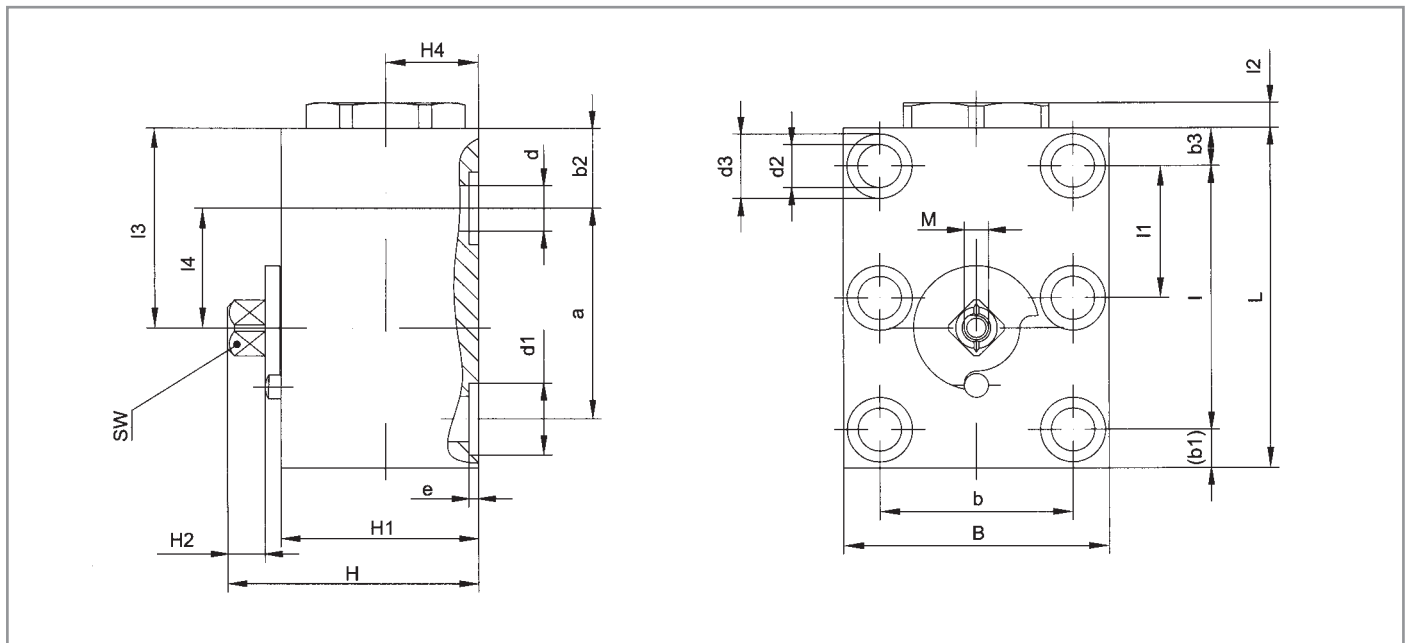

DN	PN	LW	a	B	b	b1	b2	b3	d	d1	d2	d3	H	H1	H2	H4
mm	bar	mm	mm	mm	mm	mm	mm	mm	mm	mm	mm	mm	mm	mm	mm	mm
6	500	6	39	49	35	7,5	9,5	7,5	6	13	8,5	-	49	38	8	19
10	500	10	44	55	40	8	17	8	9,5	15	9	13,5 / 8,5 tief	52	41	8	19
13	500	13	58	60	45	7,5	24,5	8	13	20	9	13,5 / 8,5 tief	61	50	8	27
20	400	20	69	70	51	11	29	10	20	30	10,5	17,5 / 10,5 tief	86	70	12	38,5
25	400	24	81	80	60	11	31	11	24	35	13	18,5 / 12,5 tief	96	80	12	45
32	315	32	96	100	78	12	40,5	17	32	40	13	19,5 / 12,5 tief	119	100	13,5	54
40	315	38	112	130	95	28,5	42,5	42,5	38	48,5	17	25 / 16,5 tief	119	100	13,5	50
50	315	48	136	150	112	38	47	47	48	55	22	33 / 21,5 tief	134	115	13,5	54

DN	e	L	l	l1	l2	l3	l4	SW	M	Gew.	Bestell-Nr.	schwarz brüniert	verzinkt
mm	mm	mm	mm	mm	mm	mm	mm	mm		kg			
6	2	57	42	-	6	31,5	22	9	M5	1,1	4692		BKHU DN06
10	2	71	55	-	6	42	25	9	M5	2	4695		4695 A
13	2	98,5	83	41,5	7	56	31,3	9	M5	2,3	4696		4696 C
20	3	118	97	48,5	7	67	38	14	M6	3,4	4699		BKHU DN20
25	3	137	115	57,5	8	74	43	14	M6	5,2	4699 A		BKHU DN25
32	3	165,5	136	68	10	90,5	50	17	M8	10,5	4700 A		4700 B
40	3	183	112	56	10	98,5	56	17	M8	15,1	auf Anfrage		BKHU DN40
50	3	221	136	68	20	115	68	17	M8	24	auf Anfrage		BKHU DN50